

Please repair

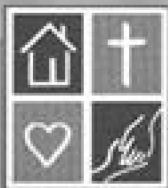

Mercy Housing

English

Introduction and acknowledgments

Part of being a good tenant is being able to communicate in an effective manner the necessary repairs to the property manager of the home or unit one is renting. In the same way, part of being a good owner or property manager is understanding the needed repairs of the tenants. The Refugee Housing Project designed this illustrated guide for home repairs to assist refugees and other tenants that speak minimal English to communicate their repair requests to their property managers.

Our intention is to provide this repair guide to service providers who work with immigrants. In addition to offering this resource to refugee resettlement agencies, mutual aid associations and other service specific organizations, we also hope to make this resource available to property owners and managers.

This guide is available for download for free at www.refugeehouse.org (*translator note: this website is no longer in service*) by clicking Resources and going to the Publications section.

The key collaborators in the project are: Carol Kimball, Artist; Scott Robins, Director of Refugee Housing Project; David Still, Maintenance Supervisor at Mercy Housing; Jennifer Gueddiche, Director of the African Community Center Program; and Joseph Thompson, Regional Director of Property Operations at Mercy Housing.

We are thankful for the translation services performed by the Interpreter Network of Colorado Springs Institute as well as the assistance of Mr. Rasulo Rasulo for the complete translation of this guide into maay maay.

For more information about the Refugee Housing Project, please contact Mercy Housing, Inc. 1999 Broadway, Suite 1000, Denver CO 80202, telephone 303-830-3300.

This document is the product of the Technical Assistance Project for the Refugee Housing Services, License Number 90RB0015. This license was awarded to Mercy Housing, Inc. by the office of Refugee Resettlement (ORR), Department of Health and Human Services of the United States of America. The point of views presented here reflect those of ORR.



Mercy Housing

Report immediately!!!



Sparks

Call 911!



**Smoke
Call 911!**



**Fire
Call 911!**

Water stain



Leak



**Call the property
manager!**

Call: _____

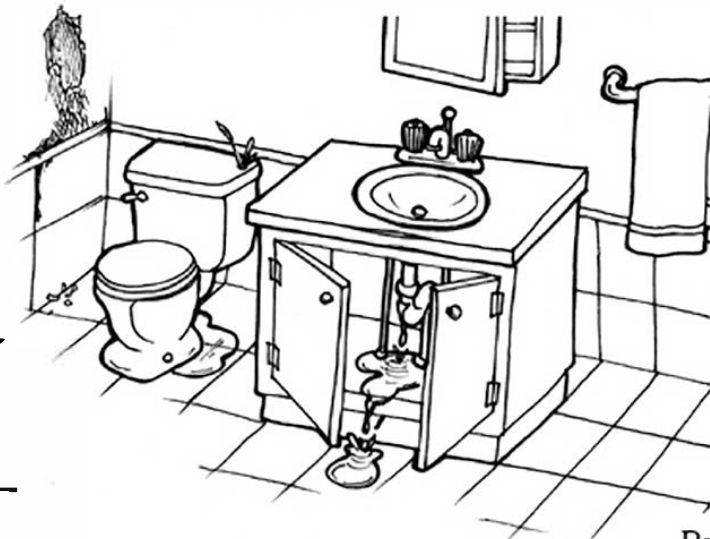

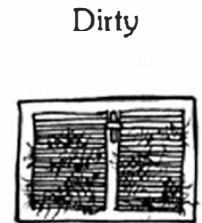
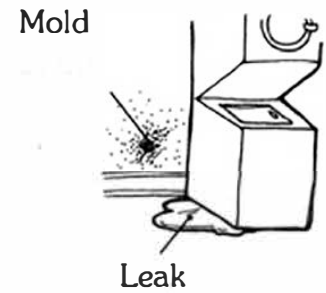
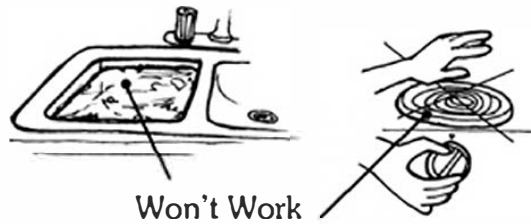

Ice



Sparks

Call 911!

Smoke

Call 911!

Fire

Call 911!



Missing

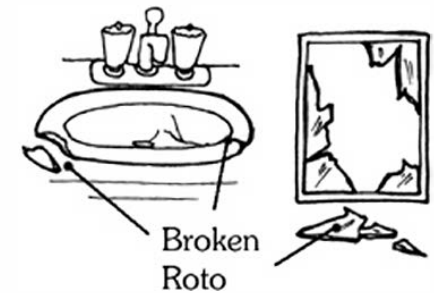
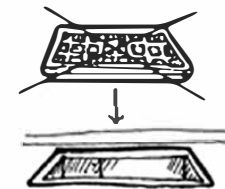

Maintenance Request:

Name of Tentant: _____

Maintenance Request #: _____

Date: _____ Unit: _____ Phone #: _____

English

Bad smell

Bathroom

Broken

Dirty

Hole

Leak

Missing

Mold

Noisy

Stain

Water stain

Won't work

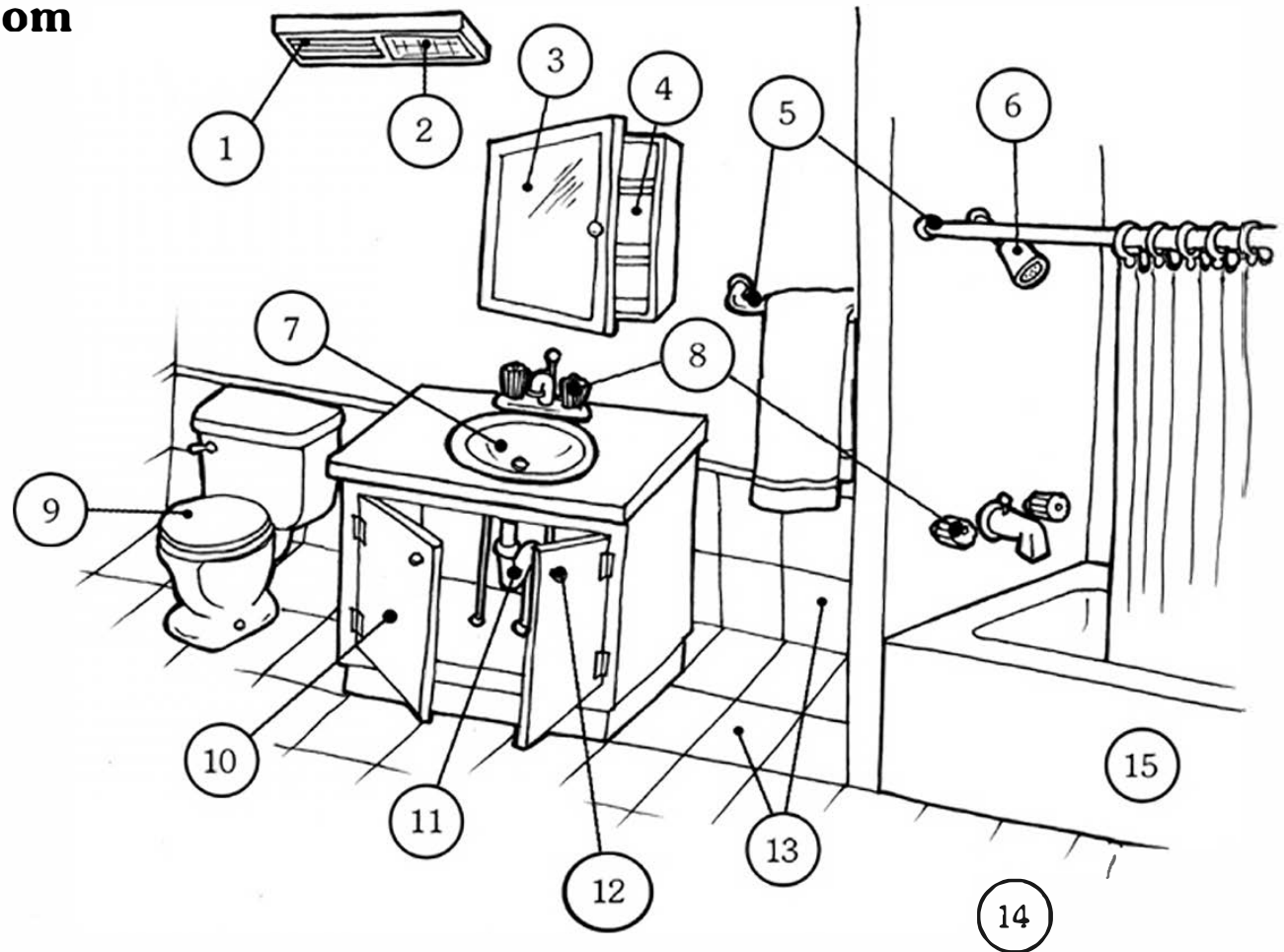

1 Fan

2 Light

3 Mirror

4 Cabinet

5 Rod

6 Shower

7 Sink

8 Faucet

9 Toilet

10 Door

11 Pipe

12 Handle

13 Tile

14 Floor

15 Tub

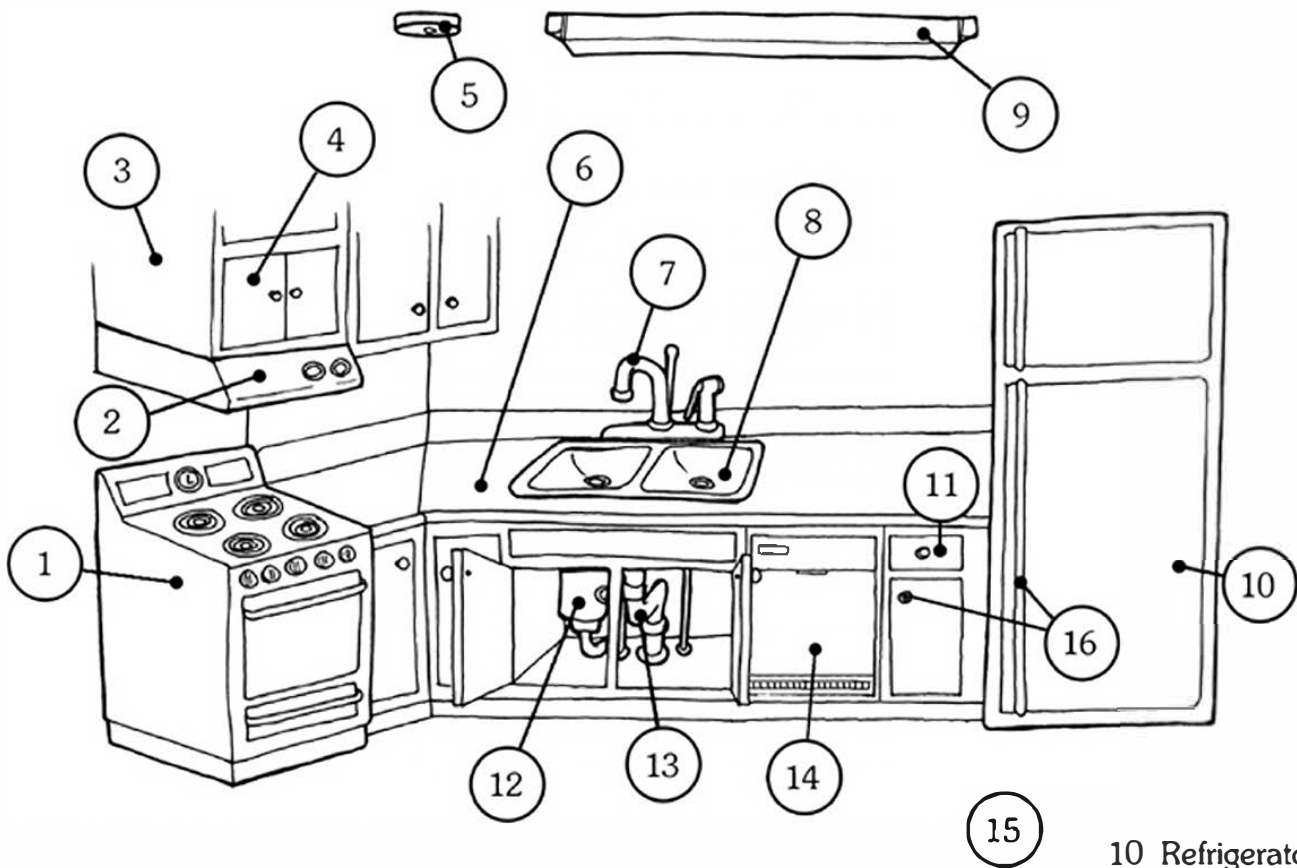

Kitchen

- Leak
- Missing
- Bad smell
- Mold
- Broken
- Noisy
- Dirty
- Stain
- Hole
- Water stain
- Won't work

- 1 Stove
- 2 Exhaust fan
- 3 Cabinet
- 4 Door
- 5 Smoke alarm
- 6 Countertop
- 7 Faucet
- 8 Sink
- 9 Light
- 10 Refrigerator
- 11 Drawer
- 12 Disposal
- 13 Pipe
- 14 Dishwasher
- 15 Floor
- 16 Handle

Maintenance Request

Name of Tenant: _____

Maintenance Request #: _____

Date: _____ Unit: _____ Phone #: _____ **English**

Bad smell

Broken

Dirty

Hole

Leak

Missing

Mold

Noisy

Stain

Water stain

Won't work

Utilities

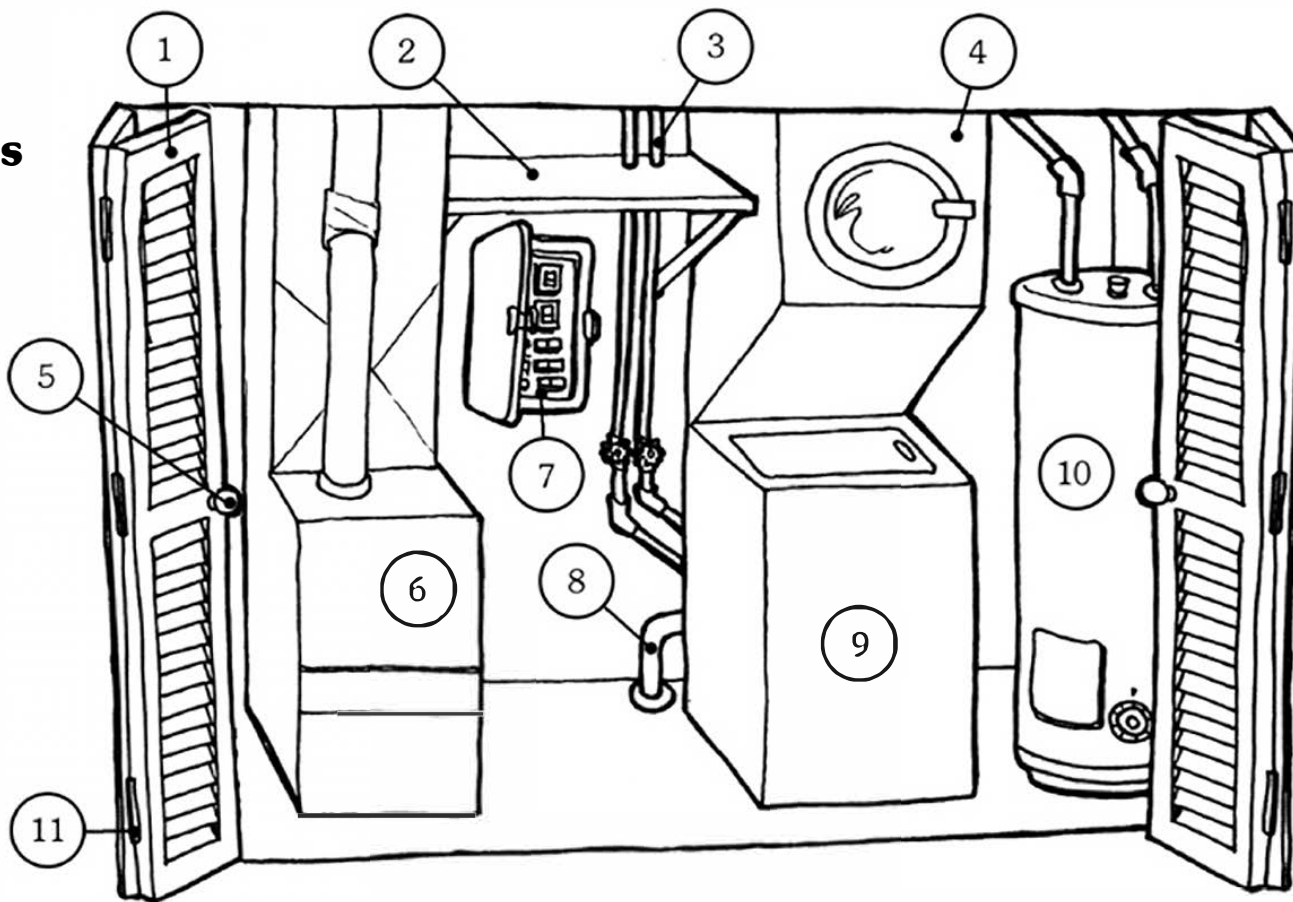

3 Pipe

6 Heater

9 Washer

1 Door

4 Dryer

7 Electric Panel

10 Water Heater

2 Shelf

5 Handle

8 Hose

11 Hinge

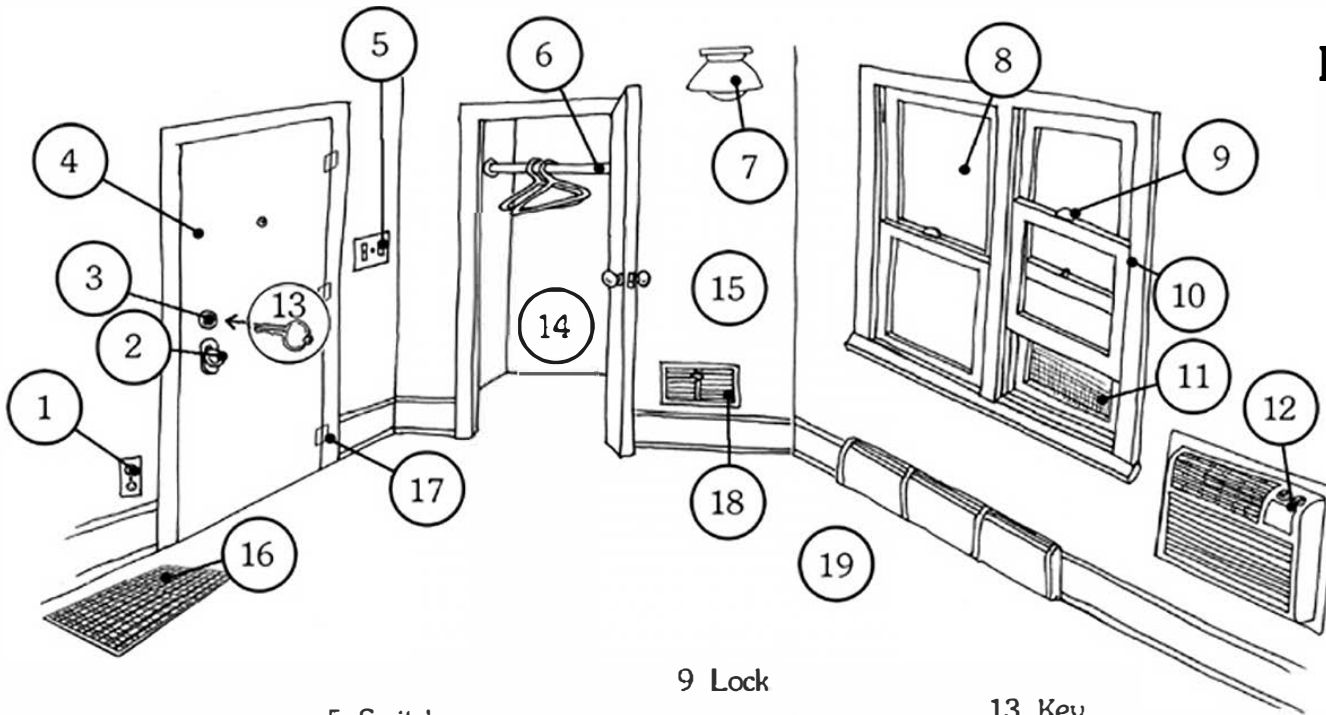

Living Areas

- Leak
- Missing
- Bad smell
- Mold
- Broken
- Noisy
- Dirty
- Stain
- Hole
- Water stain
- Won't work

1 Electric Outlet

5 Switch

9 Lock

13 Key

2 Handle

6 Rod

10 Window

14 Closet

17 Hinge

3 Lock

7 Light

11 Screen

15 Wall

18 Grille

4 Door

8 Glass

12 Heater/Cooler

16 Grille

19 Carpet/Floor

Maintenance Request

Name of tenant _____

Maintenance Request #: _____

Date: _____ Unit: _____ Phone # _____

English

Common Areas

Bad smell

Broken

Dirty

Hole

Leak

Missing

Mold

Noisy

Stain

Water stain

Won't work

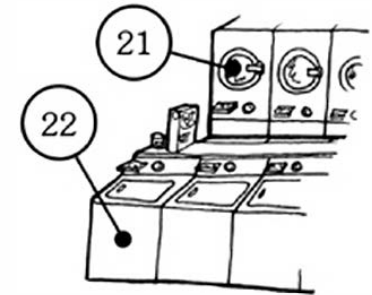
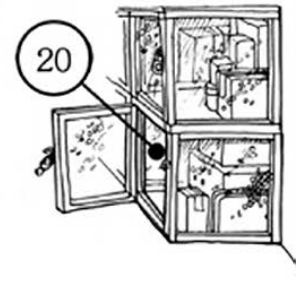
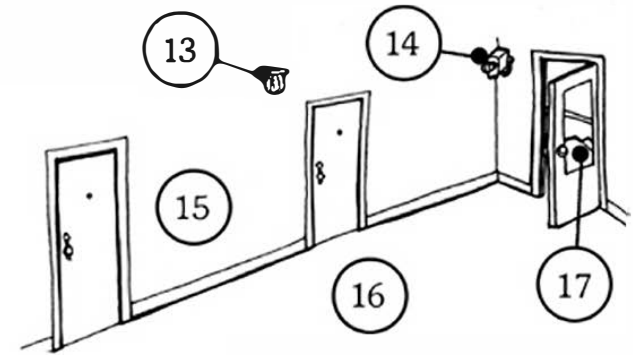
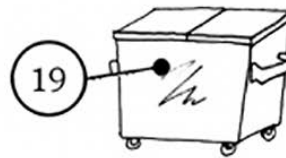
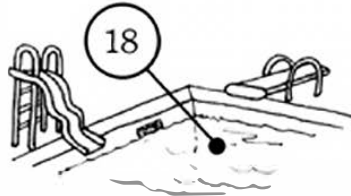
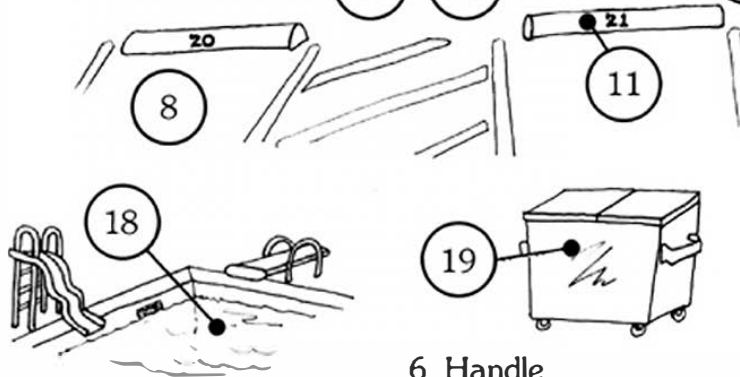
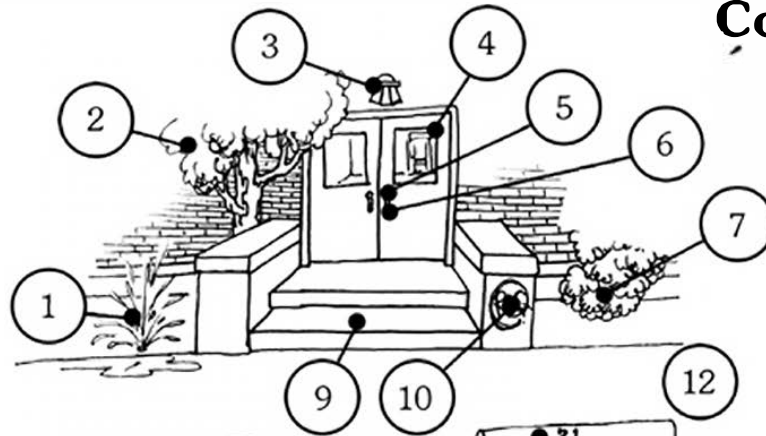

1 Sprinkler

2 Tree

3 Light

4 Door

5 Lock

6 Handle

7 Plants

8 Pavement

9 Stair

10 Graffiti

11 Parking dividers

12 Sidewalk

13 Light

14 Security camera

15 Hallway

16 Carpet

17 Stair

18 Swimming pool

19 Dumpster

20 Storage Unit

21 Dryer

22 Washer